

MGO

Laser Thickness Measurement for Boards and Panels

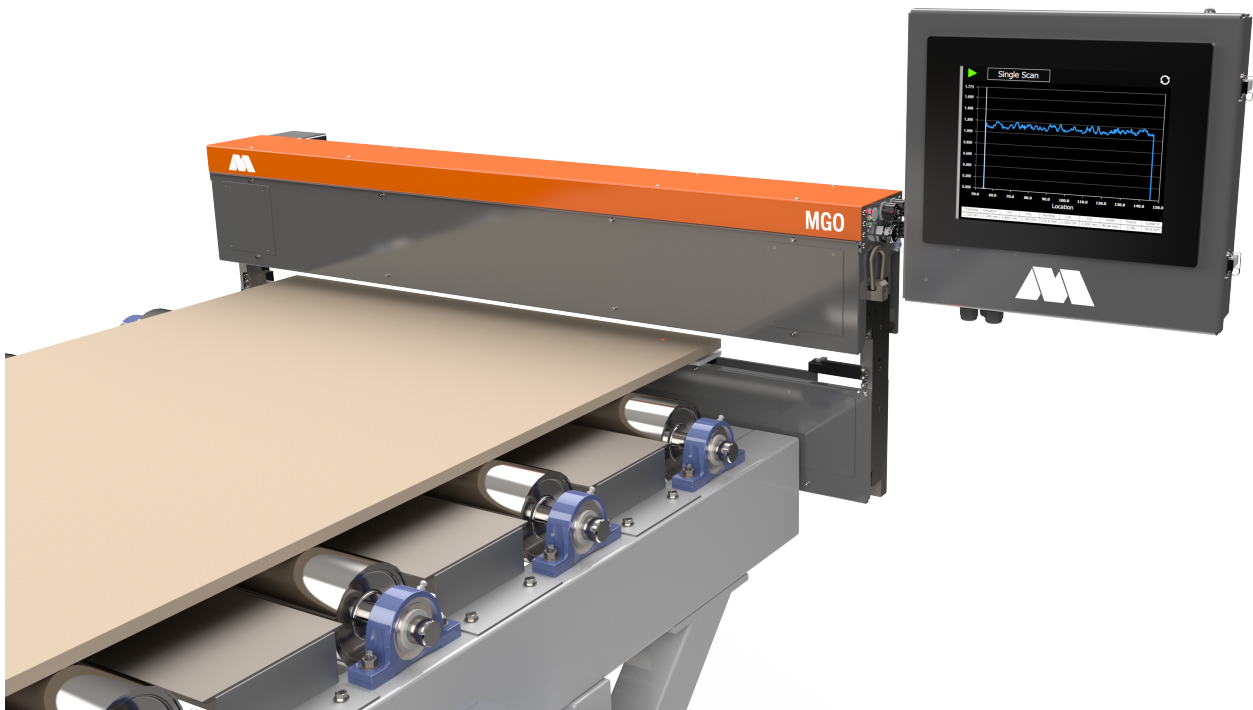

Non-contact measurement
"Gauge and Go" Measurement Mode
Dirt Detection and Alert System
Automatic Correction Scan for O-
Frame Calibration

Touchscreen display
Easily installed and maintained
Networkable
Remote support
Data logging



Contact us for more info or to order an MGO

info@mategauge.com

Go flat out with the MGO

- **Laser measurement for unmatched precision:** Laser sensors measure the uneven lumber surfaces on sanding, planing, or finishing lines. Removes the need to rely on inaccurate hand micrometer measurements and line stoppages to check product quality.
- **Continuous measuring throughout the run:** Our “gauge and go” continuous measurement system enables operators and managers to monitor board thickness during the entire operation. For more detailed thickness measurement data about sections across the sample our “Zones Scan” mode enables operators to monitor thickness of individual sections of the surface.
- **Side to side thickness measurement:** Scanning laser heads measure thickness across individual boards. Avoids relying on the outside boards to control your process.
- **Mounts directly to the line:** Engineered to blend seamlessly into your production line, the MGO can be mounted anywhere along the production line. Get all the benefits of laser measurement without the added space of a C-frame.
- **PLC connection:** Engineered to blend seamlessly into your production line, the MGO can connect directly to your PLC. This makes for easy changes in thickness, settings, and scan data. With built-in Ethernet ports, it's as simple as plug in and go.
- **Monitor thickness measurement in real-time:** Our on-screen data visualizations are purpose-built for operator ease. Monitor real-time thicknesses and run charts of multiple locations across the panel. Automatically connect to your existing systems to set thickness targets and key thresholds. Be immediately notified by on-screen alarms when issues arise.
- **Keep an eye on your lines without leaving your desk:** You'll have full access to real-time measurement data, as well as the ability to track trends over run-time and perform data file downloads. All of this with ironclad security - your data is only accessible via your facility's local network using our on-premise web application.
- **Ease of use and stress-free maintenance:** The belt-driven, single actuator includes built-in centering for in-field positioning. Calibration, using the NIST-traceable master calibration block, only needs to be done once every 3 months. The laser sensors' modular design and quick electrical disconnects means, when needed, they are quickly and easily replaced. The belt-drive actuator design is familiar making it easy to maintain.
- **Monitor and reduce debris accumulation:** Sensors with air purge covers help reduce debris buildup. However, when the sensors do get dirty, our alert system makes sure you're immediately notified. Dirty sensors are easily and quickly cleaned with no disruption to your manufacturing line.

MGO Technical Specifications

THICKNESS MEASUREMENTS DETAILS

Resolution	0.5 μm	[0.00002 in]
Accuracy (typical)	10 μm	[0.0004 in]
Stroke	1420 mm	[56 in]
Scanning Speed	0-300 mm/sec	[0-12 in/sec]
Thickness Range	0 to 20 mm	[0 to 0.8 in]
Measurement Frequency	1 to 5 kHz	

SUPPLY REQUIREMENTS

Power 4A @ 110V/60 Hz 2A @ 240V/50 Hz

WEIGHT

Complete Assembly 68 kg [150 lbs]

PHYSICAL DIMENSIONS

Main Housing 1660x585x280 mm [65x23x11 in]

ENVIRONMENTAL REQUIREMENTS

Operating Temperature 10 °C to 50 °C [50 °F to 120 °F]

Humidity < 90%

PART NUMBER

Item	Part Number	Description
1	10041911	General Assembly MGO

MGO Schematics

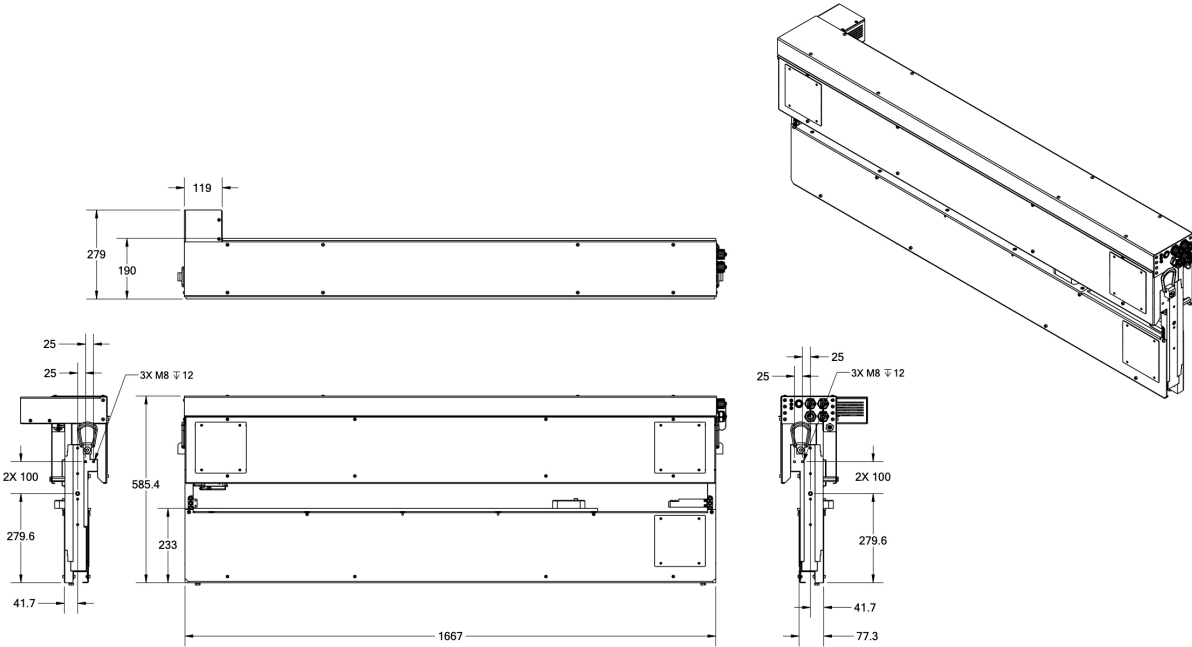
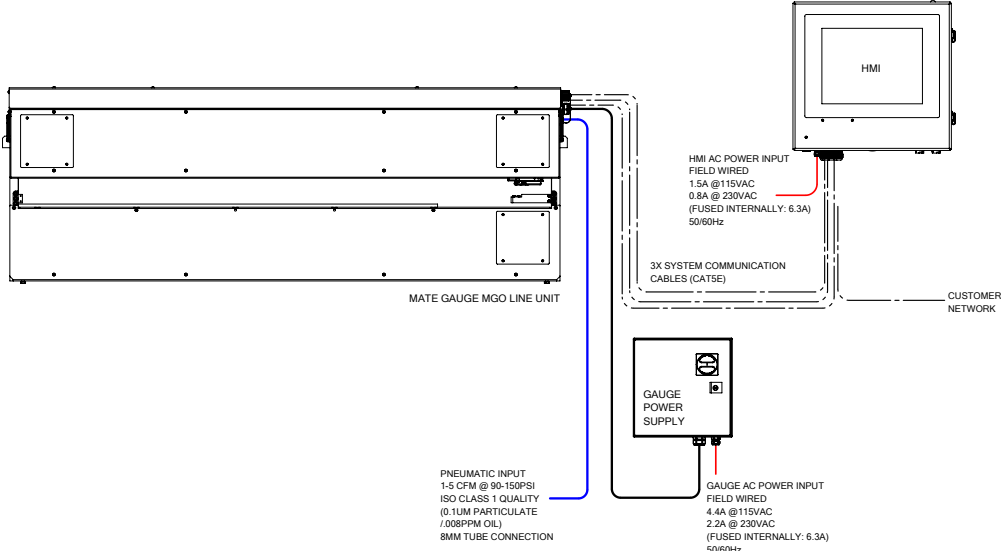

MGO Controls and Displays

Purpose-built for operator ease

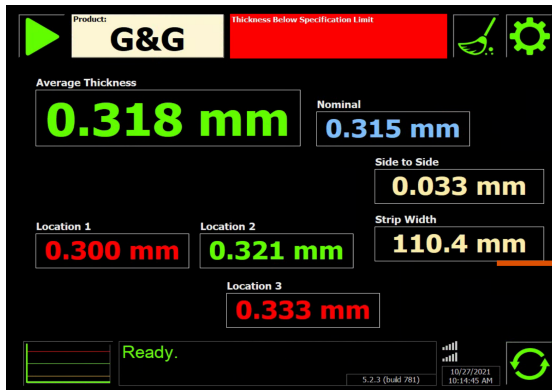

Colour coded numerical display

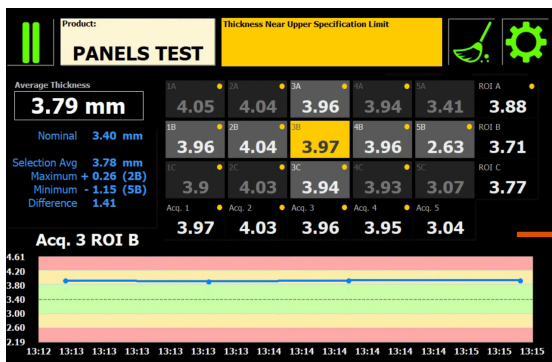

Panels app

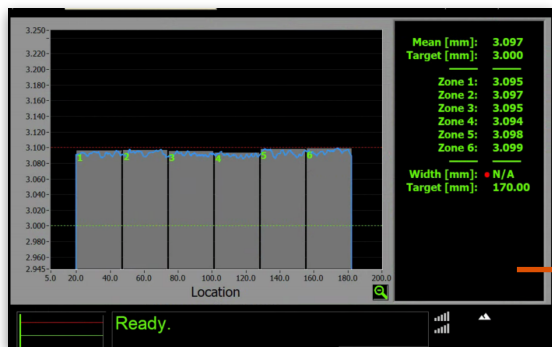

View thickness of sample in a range of zones

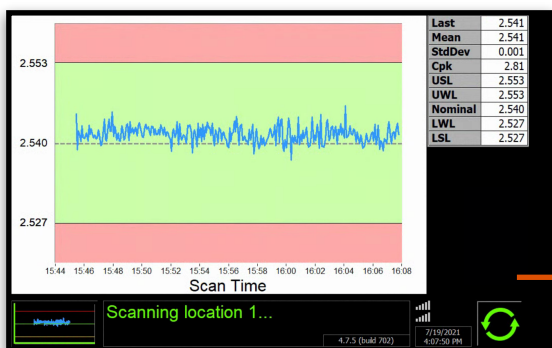

See sample thickness over time

Not sure which Mate Gauge is right for you? Check out our other



Compact and lightweight

The MG1 provides thickness measurement solutions that fit your floorspace and budget.

[Learn more](#)

Our Flagship Gauge

Tolerant of dirt and temperature swings, the MG3 provides rich data for your inline needs

[Learn more](#)

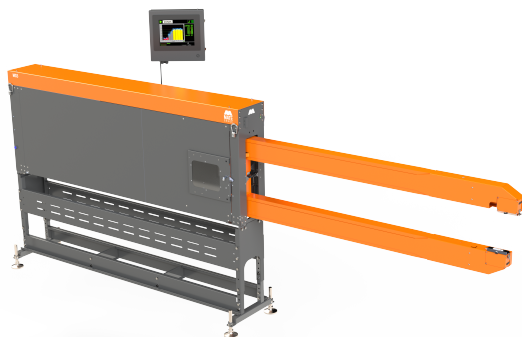
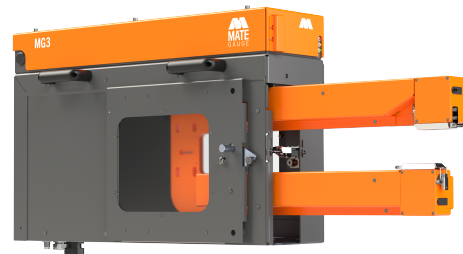

No area is out of reach

The MG5 is a large scale thickness scanner designed for wide continuous-strip materials.

[Learn more](#)

For cast lead strips

The MG-CLS improves lead strip thickness control with automatic measurement.

[Learn more](#)

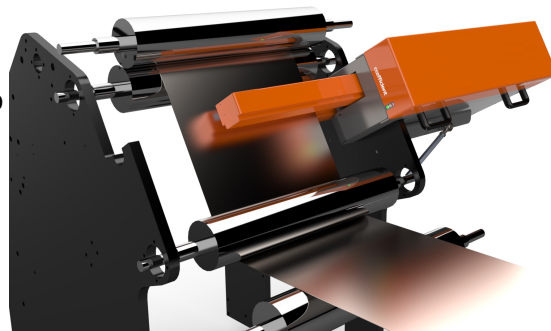

Your complete thickness measurement system